

CASH DRAWER OPERATING & MAINTENANCE

INSTRUCTIONS

This instruction sheet applies to the standard (Series 1000) and media slot (Series 2000) products with the lock mounted in the case, below the drawer front

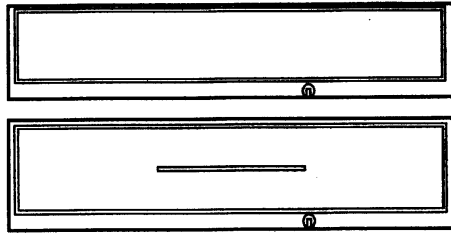

MODEL AND SERIAL NUMBER LABELS ON THE INNER DRAWER AND ON THE BASE

The Model and Serial Number label has been placed in the inner drawer and the same number has been placed on the base inside the cash drawer housing. Inner drawers should not be interchanged with one another, and the Model/SN labels are intended to make sure that the original inner drawer remains in the original cash drawer housing.

REMOVING THE INNER DRAWER FROM THE CASH DRAWER

Open the cash drawer and remove the plastic coin and bill tray. Grasp the inner drawer by the stainless steel drawer front and lift the inner drawer up until it stops. Firmly pull the inner drawer out at the inclined angle. See figure 2.

Figure 2

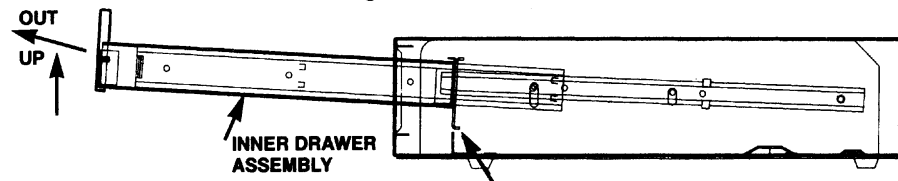

Remove the Inner Drawer by lifting up and out. Note that the strike plate attached to the inner drawer must pass over the stop plate in the base for removal or reinsertion.

REPLACING THE INNER DRAWER INTO THE CASH DRAWER

Mate the outer slides (mounted to the inner drawer) with the inner slides mounted to the chassis inside the cash drawer. Lift the inner drawer up until it stops and begin to push the inner drawer into the cash drawer housing. When the strike plate on the back of the inner drawer has cleared the stop plate formed from the base, let the inner drawer rest in the horizontal position. See figure 2. Push the inner drawer to the fully closed position. Resistance to the insertion should be expected because the ball bearings do not roll until the slides are fully engaged. When the inner drawer is fully inserted, verify that the drawer opens and closes properly using the key. The drawer should open and close smoothly through the full extent of the slides.

PREVENTIVE MAINTENANCE

Lubricate the slide assembly, latch, and strike plate periodically. Maintain a thin film of lithium based bearing grease on the ball bearings in the slides and on the strike plate at the latch point located on the back of the inner drawer. Operating conditions govern the frequency of inspection and lubrication. Under heavy use, inspect, clean, and lubricate the slide assembly and strike plate more frequently. Avoid breaking coin rolls over the plastic cash tray or on the drawer front.

LOCK ASSEMBLY

Two keys are included with each cash drawer for the manual lock. The manual key lock mechanism provides four functions: locked open, manual open, electrically on-line, and locked closed. See figure 3. To reduce the risk of damaging or breaking the key, avoid leaving it in the lock during normal operation.

Figure 3

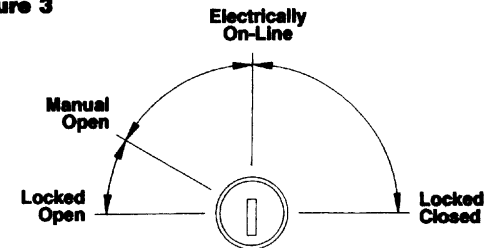

LOCK POSITIONS AND FUNCTIONS
AS VIEWED FROM FRONT

CASH DRAWER OPERATING & MAINTENANCE

INSTRUCTIONS Continued

KEY LOCK REPLACEMENT INSTRUCTIONS

A #2 Phillips head screwdriver is required to replace the key lock.

1. Remove the inner drawer from the cash drawer. See figure 2
2. Place the key lock in the vertical position and remove the key. Turn the cash drawer over with the drawer front opening toward you.
3. Remove the screws that secure the base to the case. Three are located along the back edge, and three are located along the front edge. See figure 4.

Figure 4

REMOVING THE BASE
FROM THE CASE

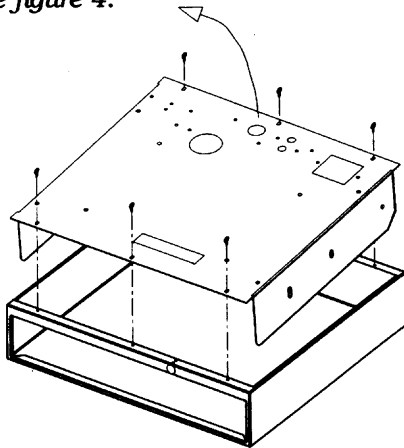

4. Lift the front edge of the base 2-3 inches and remove the lock rod from lock cam. Figure 5 illustrates an assembled lock with the lock rod attached. Remove the base from the case.

Figure 5

ASSEMBLED
LOCK MECHANISM
(FROM THE INSIDE,
RIGHT SIDE UP)

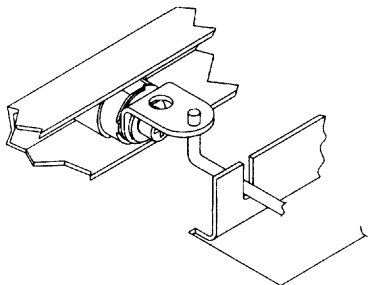

5. Figure 6 illustrates each component of the lock assembly. Remove the fillister screw, lock washer, 1/2 moon washer, cam, and cam stop.
6. Install the new lock assembly as shown in figure 6. When the cash drawer is upside-down, the key's teeth should be up, toward the bottom of the drawer, before assembling the lock.
7. Insert the key and rotate the lock 90° clockwise and 90° counter clockwise. Be sure that the lock rotates freely without sticking or binding at any point during rotation. Place the key in the vertical position and remove the key.
8. Replace the base into the case. Be sure to replace the lock rod into the lock cam. Reinsert the inner drawer into the cash drawer housing.

Figure 6

